

General Description

The GA1706 is a high performance AC/DC power supply controller for battery charger and adapter applications. The device uses Pulse Frequency Modulation (PFM) method to build discontinuous conduction mode (DCM) flyback power supplies.

The GA1706 provides constant voltage, constant current (CV/CC) regulation without requiring an opto-coupler and secondary control circuitry. It also eliminates the need of loop compensation circuitry while maintaining stability.

The GA1706 achieves excellent regulation and high power efficiency, the no-load power consumption is less than 200mW at 265VAC input.

Features

- Primary Side Control for Rectangular Constant Current and Constant Voltage Output
- Eliminates Opto-Coupler and Secondary CV/CC Control Circuitry
- Eliminates Control Loop Compensation Circuitry
- Flyback Topology in DCM Operation
- Random Frequency Modulation to Reduce System EMI
- Valley Turn on of External Power NPN Transistor
- Built-in Soft Start
- Open Circuit Protection
- Over Voltage Protection
- Short Circuit Protection

Applications

- Adapters/Chargers for Cell/Cordless Phones, PDAs, MP3 and Other Portable Apparatus
- Standby and Auxiliary Power Supplies
- LED Driver

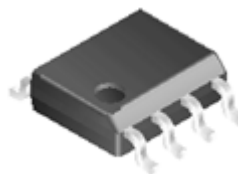

SOIC-8

Figure 1. Package Type of GA1706

Pin Configuration

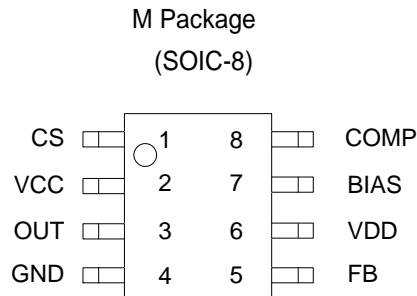

Figure 2. Pin Configuration of GA1706 (Top View)

Pin Description

Pin Number	Pin Name	Function
1	CS	The primary current sense
2,	VCC	Supply voltage
3	OUT	This pin drives the base of external power NPN switch
4	GND	Ground
5	FB	The voltage feedback from the auxiliary winding
6	VDD	The 5V output of the internal voltage regulator
7	BIAS	This pin sets the bias current inside GA1706 with an external resistor to GND
8	COMP	This pin connects a bypass capacitor for CC function

Functional Block Diagram

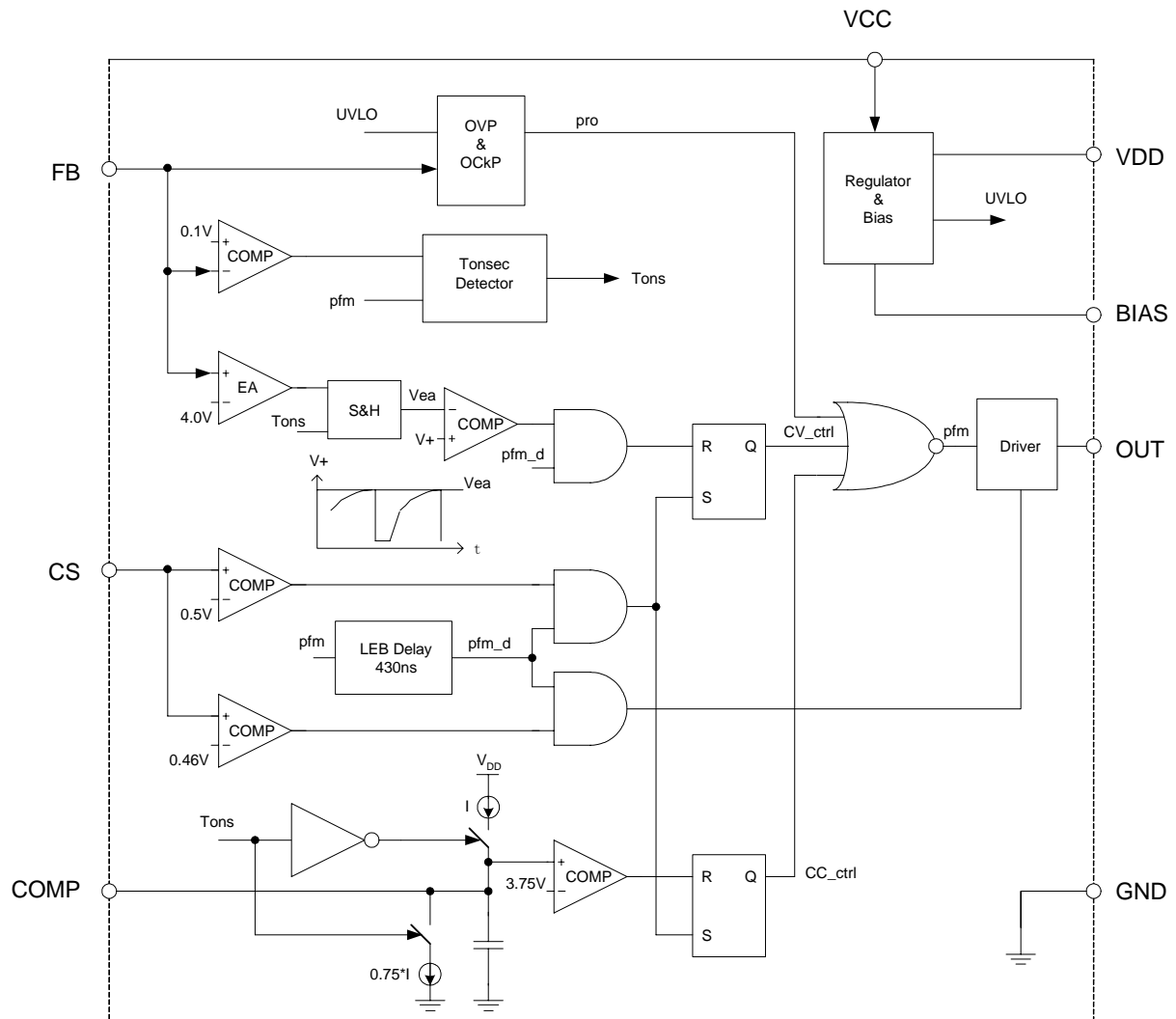
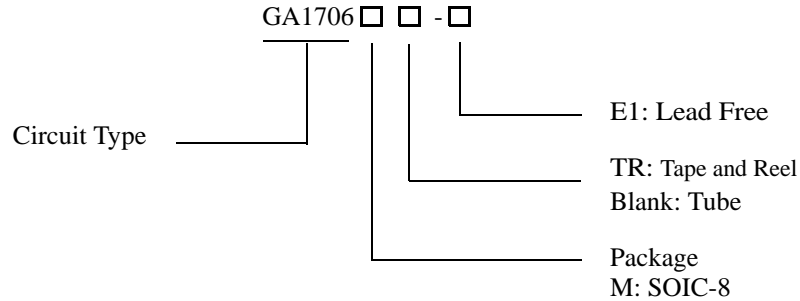

Figure 3. Functional Block Diagram of GA1706

Ordering Information



Package	Temperature Range	Part Number	Marking ID	Packing Type
SOIC-8	-40 to 85°C	GA1706M-E1	1706M-E1	Tube
		GA1706MTR-E1	1706M-E1	Tape & Reel

GA Semiconductor's Pb-free products, as designated with "E1" suffix in the part number, are RoHS compliant.

Absolute Maximum Ratings (Note 1)

Parameter	Value	Unit
Supply Voltage VCC	-0.3 to 30	V
Voltage at CS, BIAS, OUT, VDD, COMP to GND	-0.3 to 7	V
FB input (Pin 5)	-20 to 10	V
Output Current at OUT	Internally limited	A
Power Dissipation at T _A =25°C	0.657	W
Operating Junction Temperature	150	°C
Storage Temperature	-65 to 150	°C
Lead Temperature (Soldering, 10s)	300	°C
Thermal Resistance Junction-to-Ambient	190	°C/W
ESD (Machine Model)	200	V

Note 1: Stresses greater than those listed under "Absolute Maximum Ratings" may cause permanent damage to the device. These are stress ratings only, and functional operation of the device at these or any other conditions beyond those indicated under "Recommended Operating Conditions" is not implied. Exposure to "Absolute Maximum Ratings" for extended periods may affect device reliability.



Electrical Characteristics

($V_{CC}=15V$, $T_A=25^{\circ}C$, unless otherwise specified.)

Parameter	Symbol	Conditions	Min	Typ	Max	Unit
UVLO SECTION						
Start-up Threshold	$V_{TH(ST)}$		17.2	18.2	19.2	V
Minimal Operating Voltage	$V_{OPR(min)}$	After turn on	6.7	7.4	8.1	V
REFERENCE VOLTAGE SECTION						
BIAS Pin Voltage	V_{BIAS}	$R_{BIAS}=200k\Omega$ Before turn on	1.170	1.205	1.240	V
VDD Pin Voltage	VDD		4.75	5.0	5.25	V
STANDBY CURRENT SECTION						
Start-up Current	I_{ST}	$V_{CC} = V_{TH(ST)} - 0.5V$, $R_{BIAS}=200k\Omega$, Before turn on		70	80	μA
Operating Current	$I_{CC(OPR)}$	$R_{BIAS}=200k\Omega$		680	900	μA
DRIVE OUTPUT SECTION						
OUT Maximum Current	Sink	I_{OUT}	$R_{BIAS}=200k\Omega$	50		mA
	Source			25	30	
CURRENT SENSE SECTION						
Current Sense Threshold	V_{CS}		480	500	520	mV
Pre-Current Sense	$V_{CS(PRE)}$		440	460	480	mV
Leading Edge Blanking				430		ns
FEEDBACK INPUT SECTION						
Feedback Threshold	V_{FB}		3.90	4.00	4.10	V
Enable Turn-on Voltage	$V_{FB(EN)}$		-0.9	-0.7	-0.5	V
COMP THRESHOLD VOLTAGE SECTION						
Turn-on Threshold Voltage	V_{COMP}		3.42	3.60	3.78	V
PROTECTION SECTION						
Over Voltage Protection	$V_{FB(OVP)}$		7	8	9	V

Typical Performance Characteristics

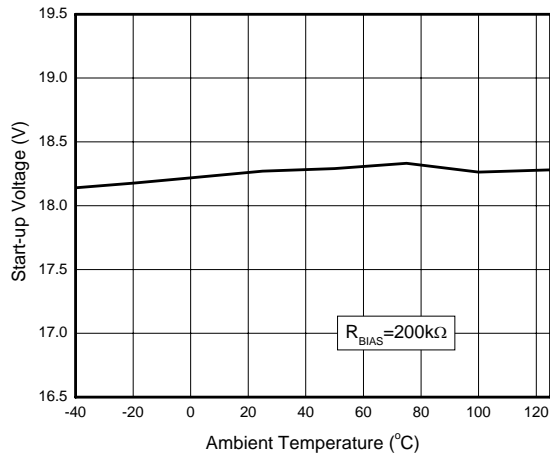

Figure 4. Start-up Voltage vs. Ambient Temperature

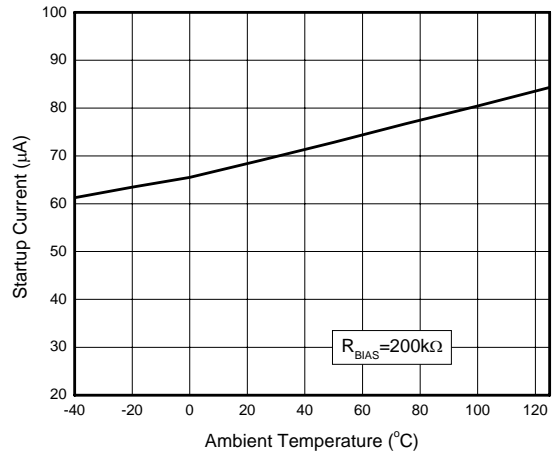

Figure 5. Start-up Current vs. Ambient Temperature

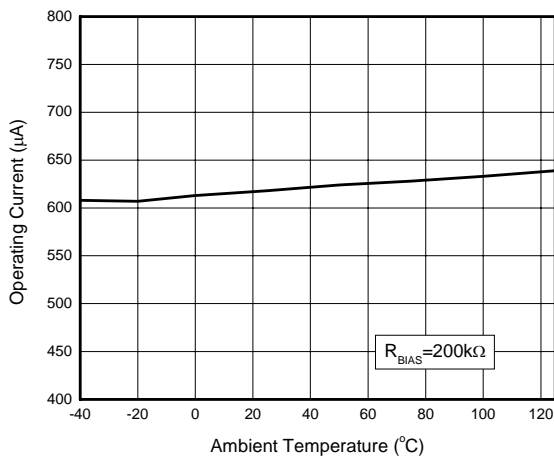

Figure 6. Operating Current vs. Ambient Temperature

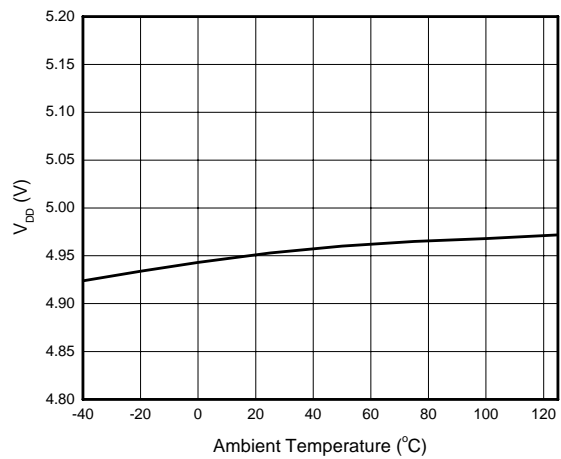

Figure 7. V_{DD} vs. Ambient Temperature

Typical Performance Characteristics (Continued)

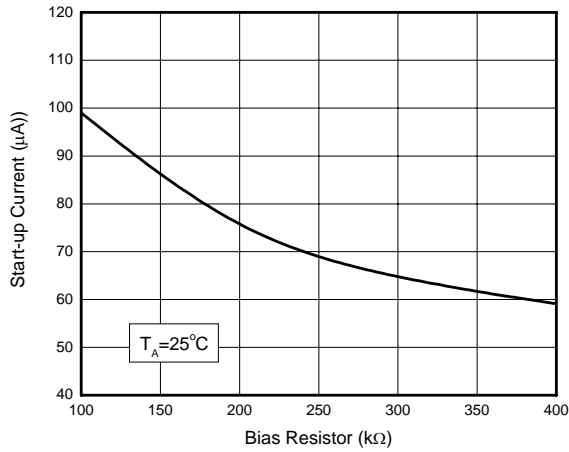

Figure 8. Start-up Current vs. Bias Resistor

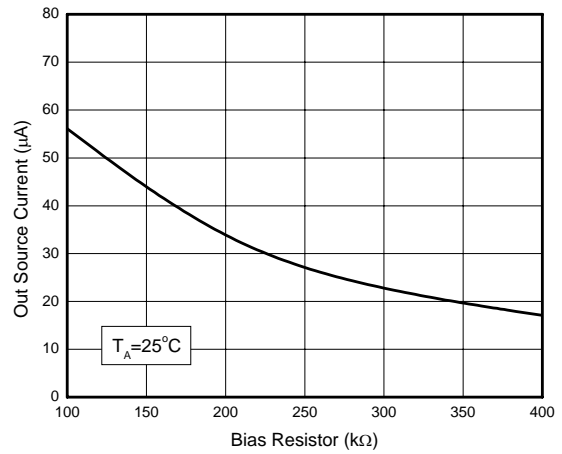

Figure 9. OUT Source Current vs. Bias Resistor

Operation Description

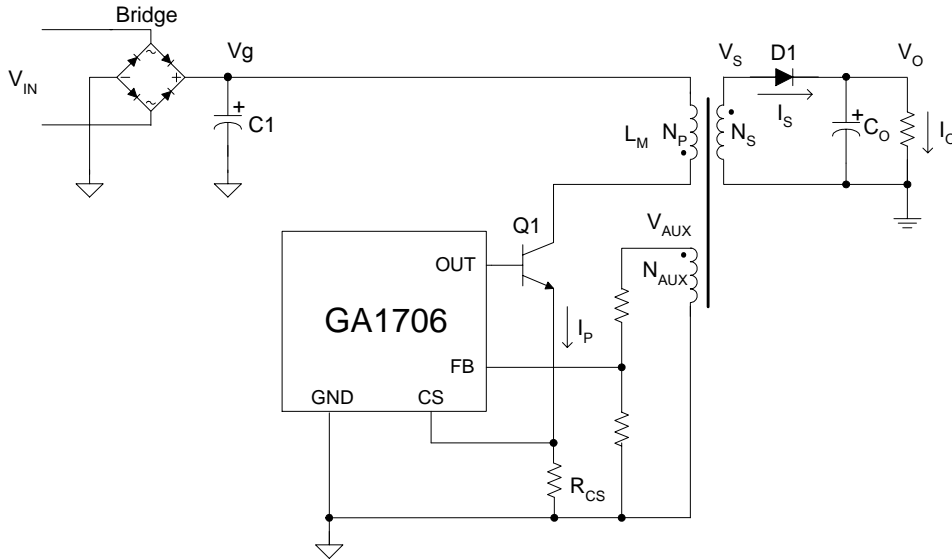

Figure 10. Simplified Flyback Converter Controlled by GA1706

Figure 10 illustrates a simplified flyback converter controlled by GA1706.

The energy stored in the magnetizing inductance LM each cycle is therefore:

Constant Primary Peak Current

The primary current ip(t) is sensed by a current sense resistor Rcs as shown in Figure 10.

$$Eg = \frac{1}{2} \cdot L_M \cdot I_{pk}^2 \quad \dots\dots\dots(3)$$

The current rises up linearly at a rate of:

So the power transferring from the input to the output is given by:

$$\frac{dip(t)}{dt} = \frac{vg(t)}{L_M} \quad \dots\dots\dots(1)$$

$$P = \frac{1}{2} \cdot L_M \cdot I_{pk}^2 \cdot f_{SW} \quad \dots\dots\dots(4)$$

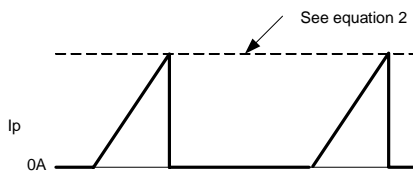

Figure 11. Primary Current Waveform

Where the fsw is the switching frequency. When the peak current Ipk is constant, the output power depends on the switching frequency fsw.

As illustrated in Figure 11, when the current ip(t) rises up to Ipk, the switch Q1 turns off. The constant peak current is given by:

Constant Voltage Operation

The GA1706 captures the auxiliary winding feedback voltage at FB pin and operates in constant-voltage (CV) mode to regulate the output voltage. Assuming the secondary winding is master, the auxiliary winding is slave during the D1 on-time. The auxiliary voltage is given by:

$$I_{pk} = \frac{V_{CS}}{R_{CS}} \quad \dots\dots\dots(2)$$

$$V_{AUX} = \frac{N_{AUX}}{N_S} \cdot (V_o + V_d) \quad \dots\dots\dots(5)$$

Operation Description (Continued)

Where the V_d is the diode forward drop voltage.

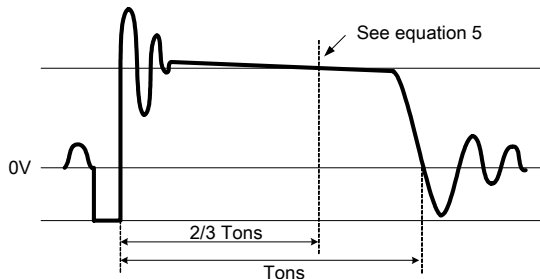

Figure 12. Auxiliary Voltage Waveform

The output voltage is different from the secondary voltage in a diode forward drop voltage. The diode drop voltage depends on the current. If the secondary voltage is always detected at a constant secondary current, the difference between the output voltage and the secondary voltage will be a fixed V_d . The voltage detection point is at two-thirds of the D1 on-time. The CV loop control function of GA1706 then generates a D1 off-time to regulate the output voltage.

Constant Current Operation

The GA1706 is designed to work in constant-current (CC) mode. Figure 13 shows the secondary current waveforms.

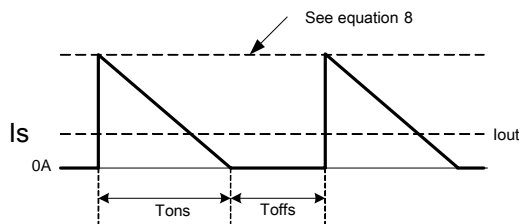

Figure 13. Secondary Current Waveform

In CC operation, the CC loop control function of GA1706 will keep a fixed proportion between D1 on-time T_{ons} and D1 off-time T_{offs} by discharging or charging the capacitance connected in COMP pin. The fixed proportion is

$$\frac{T_{ons}}{T_{offs}} = \frac{4}{3} \dots\dots\dots(6)$$

The relationship between the output constant-current and secondary peak current I_{pks} is given by:

$$I_{out} = \frac{1}{2} \cdot I_{pks} \cdot \frac{T_{ons}}{T_{ons} + T_{offs}} \dots\dots\dots(7)$$

At the instant of D1 turn-on, the primary current transfers to the secondary at an amplitude of:

$$I_{pks} = \frac{N_p}{N_s} \cdot I_{pk} \dots\dots\dots(8)$$

Thus the output constant-current is given by:

$$I_{out} = \frac{1}{2} \cdot \frac{N_p}{N_s} \cdot I_{pk} \cdot \frac{T_{ons}}{T_{ons} + T_{offs}} = \frac{2}{7} \cdot \frac{N_p}{N_s} \cdot I_{pk} \dots\dots\dots(9)$$

Leading Edge Blanking

When the power switch is turned on, a turn-on spike will occur on the sense-resistor. To avoid false-termination of the switching pulse, a 430ns leading-edge blanking is built in. During this blanking period, the current sense comparator is disabled and the gate driver can not be switched off.

CCM Protection

The GA1706 is designed to operate in discontinuous conduction mode (DCM) in both CV and CC modes. To avoid operating in continuous conduction mode (CCM), the GA1706 detects the falling edge of the FB input voltage on each cycle. If a 0.1V falling edge of FB is not detected, the GA1706 will stop switching.

OVP & OCKP

The GA1706 includes output over-voltage protection (OVP) and open circuit protection (OCKP) circuitry as shown in Figure 14. If the voltage at FB pin exceeds 8V, 100% above the normal detection voltage, or the -0.7V falling edge of the FB input can not be monitored, the GA1706 will immediately shut off and enters hiccup mode. The GA1706 sends out a fault detection pulse every 8ms in hiccup mode until the fault has been removed.

Operation Description (Continued)

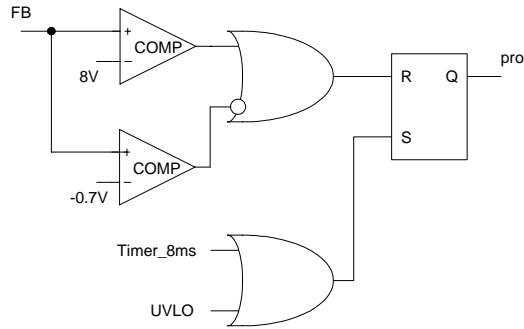

Figure 14. OVP and OCP Function Block

Typical Application

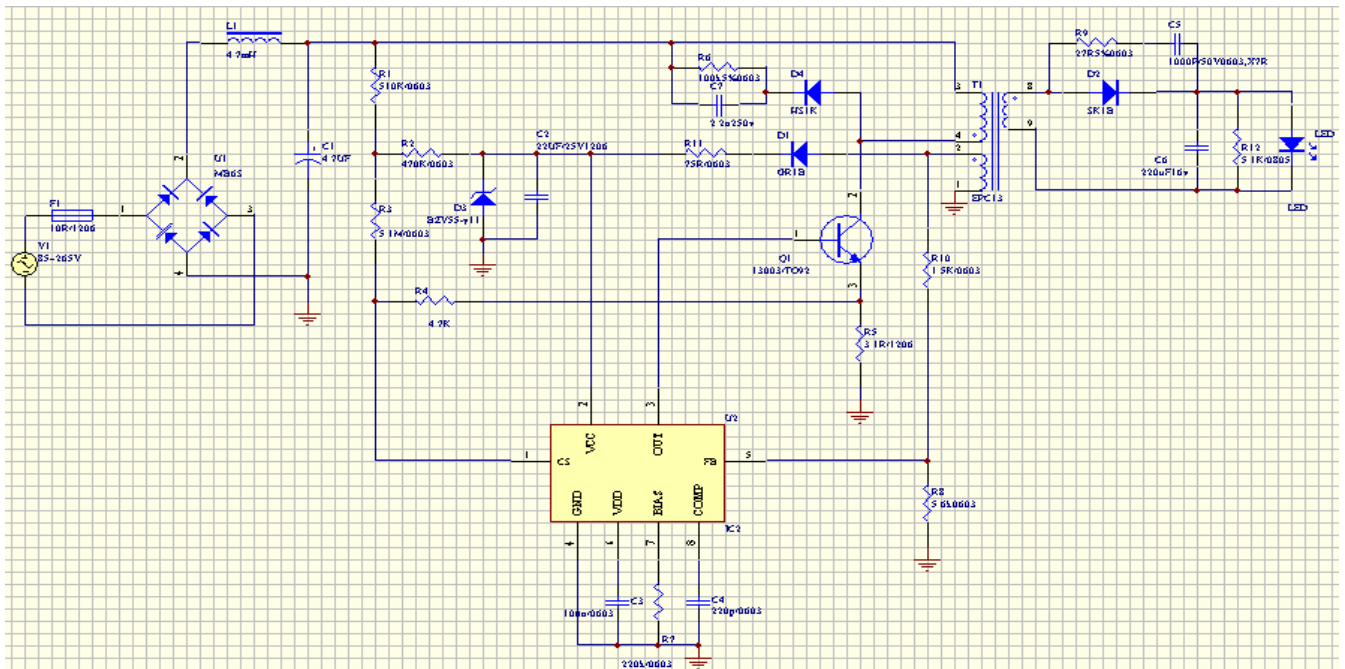

Figure 10. 5V/0.3A Output for LED power

Mechanical Dimensions

SOIC-8

Unit: mm(inch)

